

Model		SCP-A116VH5		
Main power supply		V/Ph/Hz 230/1/50		
HEATING MODE (HEAT PUMP)	WATER OUTLET 25	<i>Conditions : water inlet / outlet temperature 22/25 and air inlet temperature 7/6 (dry/wet)</i>		
		Nominal heating capacity (net)	kW	11.25
		COP	W/W	6.23
		Nominal water flow	m ³ /h	2.90
		<i>Conditions : water inlet / outlet temperature */25 and air inlet temperature -7/-8 (dry/wet)</i>		
		Maximum heating capacity (net)	kW	
	COP	W/W		
	WATER OUTLET 35	<i>Conditions : water inlet / outlet temperature 30/35 and air inlet temperature 7/6 (dry/wet)</i>		
		Nominal heating capacity (net)	kW	10.70
		Nominal input power (net)	kW	2.14
		COP	W/W	5
		Nominal water flow	m ³ /h	1.84
		Maximum available pump head (at max pump speed)	kPa	45
		Minimum heating capacity (net)	kW	3.50
		COP	W/W	4.09
		Maximum heating capacity (net)	kW	15
		COP	W/W	4.49
		Water flow	m ³ /h	2.59
		<i>Conditions : water inlet / outlet temperature */35 and air inlet temperature 2/1 (dry/wet)</i>		
		Nominal heating capacity (net)	kW	7.8
		COP	W/W	3.48
		Maximum heating capacity (net)	kW	10.10
		COP	W/W	3.18
		<i>Conditions : water inlet / outlet temperature */35 and air inlet temperature -7/-8 (dry/wet)</i>		
		Nominal heating capacity (net)	kW	6.50
		COP	W/W	2.81
		Maximum heating capacity (net)	kW	9.80
		COP	W/W	2.73
		<i>Conditions : water inlet / outlet temperature */35 and air inlet temperature 10/9 (dry/wet)</i>		
		Nominal heating capacity (net)	kW	
COP		W/W		
Maximum heating capacity (net)	kW			
COP	W/W			
<i>Conditions : water inlet / outlet temperature */35 and air inlet temperature 12/11 (dry/wet)</i>				
Minimum heating capacity (net)	kW	4.10		
COP	W/W	5.07		
Maximum heating capacity (net)	kW	16.80		
COP	W/W	5.19		

Model		SCP-A116VH5	
Main power supply		V/Ph/Hz	230/1/50
HEATING MODE (HEAT PUMP)	WATER OUTLET 45	Conditions : water inlet / outlet temperature 40/45 and air inlet temperature 7/6 (dry/wet)	
		Nominal heating capacity (net)	kW 9.75
		Nominal input power (net)	kW 2.59
		COP	WW 3.76
		Nominal water flow	m ³ /h 1.75
		Maximum available pump head (at max pump speed)	kPa 47
		Minimum heating capacity (net)	kW 4.25
		COP	WW 3.04
		Maximum heating capacity (net)	kW 13.85
		COP	WW 3.53
		Water flow	m ³ /h 2.45
		Conditions : water inlet / outlet temperature */45 and air inlet temperature 2/1 (dry/wet)	
		Nominal heating capacity (net)	kW 8.10
		COP	WW 2.81
		Maximum heating capacity (net)	kW 9.75
	COP	WW 2.71	
	Conditions : water inlet / outlet temperature */45 and air inlet temperature -7/-8 (dry/wet)		
	Nominal heating capacity (net)	kW 6.30	
	COP	WW 2.28	
	Maximum heating capacity (net)	kW 8.50	
	COP	WW 2.21	
	Conditions : water inlet / outlet temperature */45 and air inlet temperature 12/11 (dry/wet)		
	Minimum heating capacity (net)	kW 5.50	
	COP	WW 4	
	Maximum heating capacity (net)	kW 15.40	
	COP	WW 3.96	
	WATER OUTLET 55	Conditions : water inlet / outlet temperature 47/55 and air inlet temperature 7/6 (dry/wet)	
Nominal heating capacity (net)		kW	
COP		WW	
Nominal water flow		m ³ /h	
Maximum available pump head (at max pump speed)		kPa	
Maximum heating capacity (net)		kW 11.30	
COP		WW 2.84	
Conditions : water inlet / outlet temperature */55 and air inlet temperature -7/-8 (dry/wet)			
Maximum heating capacity (net)	kW 6.80		
COP	WW 1.77		
COOLING MODE	WATER OUTLET 18	Conditions : water inlet / outlet temperature 23/18 and air inlet temperature 35	
		Nominal cooling capacity (net)	kW 10.80
		Nominal input power (net)	kW 2.59
		EER	WW 4.17
		Nominal water flow	m ³ /h 1.81
		Maximum available pump head (at max pump speed)	kPa 45
		Maximum cooling capacity (net)	kW 11.7
		EER	WW 3.87
	Water flow	m ³ /h 2	
	WATER OUTLET 7	Conditions : water inlet / outlet temperature 12/7 and air inlet temperature 35	
		Maximum cooling capacity (net)	kW 7.90
		EER	WW 2.86
		Water flow	m ³ /h 1.30

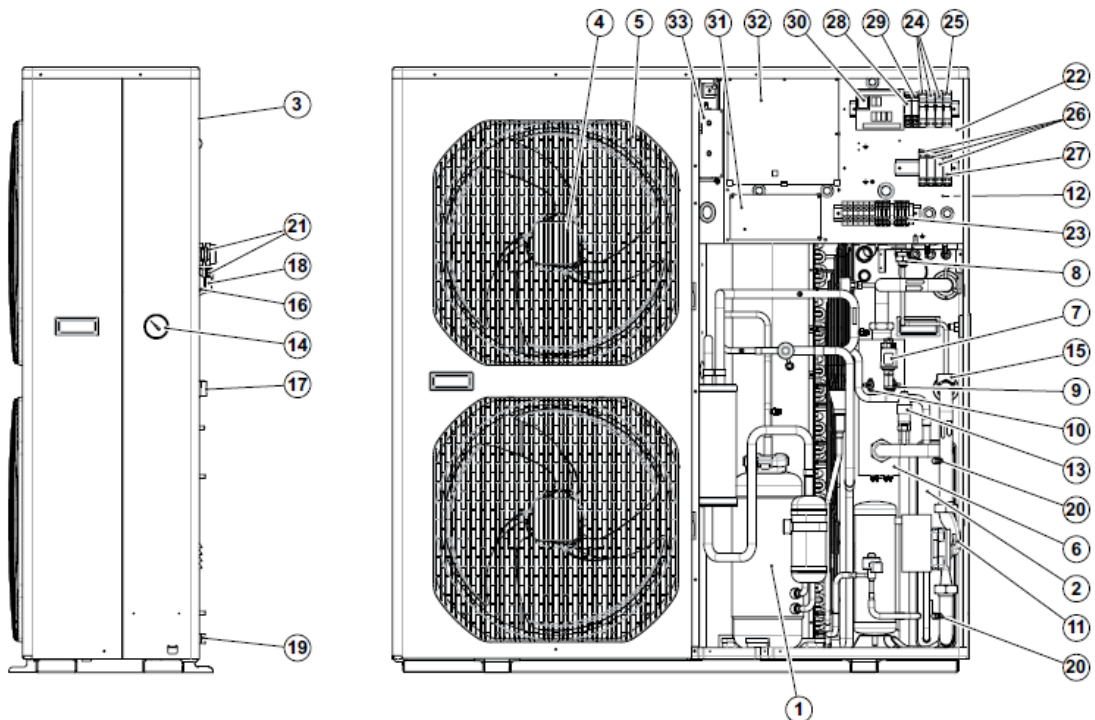

- 1 - Sound-proofed hermetic compressor.
- 2 - Brazed plate heat exchanger.
- 3 - "Plate-Fin" air heat exchanger.
- 4 - Fan motor.
- 5 - Fan protection grille.
- 6 - Electric heater:
 - 4 kW: 1st stage = 2 kW; 2nd stage = 2 kW.
 - 6 kW: 1st stage = 4 kW; 2nd stage = 2 kW.
- 7 - Frigorific pressure sensor.
- 8 - Water pressostat.
- 9 - Automatic reset safety thermostat (heater).
- 10 - Manual reset safety thermostat (heater).
- 11 - Circulating pump.
- 12 - Expansion vessel.
- 13 - Safety valve.
- 14 - Hydraulic system pressure gauge.
- 15 - Water flow switch.
- 16 - Hydraulic circuit manual air purge valve.
- 17 - Water inlet connection.
- 18 - Water outlet connection.
- 19 - Hydraulic circuit fill / drain connection.

- 20 - Water system pressure tap for flow control.
- 21 - Electrical cable passage.
- 22 - Electrical box.
- 23 - Terminals block.
- 24 - Heating element circuit breakers.
- 25 - Control circuit circuit-breaker.
- 26 - Heating element contactors.
- 27 - Circulator contactor.
- 28 - Fault relay.
- 29 - Water flow relay.
- 30 - System control board.
- 31 - CWC2 control board.
- 32 - Power board.
- 33 - HIC board.

Materials:

- Copper piping.
- Copper / aluminium air heat exchanger.
- Stainless steel water heat exchanger.
- Painted sheet metal cabinet.
- Plastic grille.

Note: The units are supplied with a water filter which is to be installed on the water intake.